



Hewlett Packard
Enterprise

HPE 1820 Switch Series Installation and Getting Started Guide

Part Number: 5998-5835S
Published: June 2016
Edition: 3

© Copyright 2016 Hewlett Packard Enterprise Development LP

The information contained herein is subject to change without notice. The only warranties for Hewlett Packard Enterprise products and services are set forth in the express warranty statements accompanying such products and services. Nothing herein should be construed as constituting an additional warranty. Hewlett Packard Enterprise shall not be liable for technical or editorial errors or omissions contained herein.

Confidential computer software. Valid license from Hewlett Packard Enterprise required for possession, use, or copying. Consistent with FAR 12.211 and 12.212, Commercial Computer Software, Computer Software Documentation, and Technical Data for Commercial Items are licensed to the U.S. Government under vendor's standard commercial license.

Applicable Products

- HPE OfficeConnect 1820 8G Switch (J9979A)
- HPE OfficeConnect 1820 24G Switch (J9980A)
- HPE OfficeConnect 1820 48G Switch (J9981A)
- HPE OfficeConnect 1820 8G PoE+ (65W) Switch (J9982A)
- HPE OfficeConnect 1820 24G PoE+ (185W) Switch (J9983A)
- HPE OfficeConnect 1820 48G PoE+ (370W) Switch (J9984A)

Contents

1	Switch Overview	5
	Switch Hardware Features	6
	Network Ports	8
	LEDs	9
	Mode Button	9
	Reset Button	10
	Power Connector	10
	Switch Features	10
2	Installing the Switch	13
	Included Parts	13
	Installation Precautions	17
	Installation Procedure	18
	1. Prepare the Installation Site	18
	2. Verify the Switch Passes Self Test	19
	3. Mount the Switch	22
	4. Connect the Switch to a Power Source	25
	5. Connect the Network Cables	26
	6. Installing or Removing SFPs	26
3	Configuring the Switch	29
	Initial Configuration	29
	Using the 192.168.1.1 IP Address	30
	Where to Go From Here	30
4	Troubleshooting	31
	Basic Troubleshooting Tips	31
	Diagnosing with the LEDs	31
	LED patterns for General Switch Troubleshooting	31
	Diagnostic Tips	32
	LED Patterns for PoE Troubleshooting	33
	Testing the Switch by Resetting It	33
	Restoring to Factory Defaults	33
	Accessing Hewlett Packard Enterprise Support	34
A	Specifications	35
	Switch Specifications	35
	Physical	35
	Electrical	35
	Environmental	35
	Acoustics	36
	Safety	36
	Standards	36
	Cabling and Technology Information Specifications	36
	Technology Distance Specifications	37
	Mode Conditioning Patch Cord	37
	Installing the Patch Cord	38
	Twisted-Pair Cable/Connector Pin-Outs	38
	Straight-through Twisted-Pair Cable for 10 Mbps or 100 Mbps Network Connections	39

Crossover Twisted-Pair Cable for 10 Mbps or 100 Mbps Network Connection.....	40
Straight-Through Twisted-Pair Cable for 1000 Mbps Network Connections.....	41
B EMC Regulatory Statements.....	43
Regulatory Statements.....	43
U.S.A.....	43
Canada.....	43
Australia/New Zealand.....	43
Japan.....	43
Korea.....	43
Taiwan.....	43
 Index.....	 45

1 Switch Overview

The HPE OfficeConnect 1820 Switch Series are multiport switches that can be used to build high-performance switched workgroup networks. These switches are store-and-forward devices that offer low latency for high-speed networking. Three of the switches also support the IEEE 802.3at standard for providing PoE+ power to connected devices.

Throughout this manual, these switches will be referred to as the 1820 8G Switch, 1820 24G Switch, 1820 48G Switch, 1820 8G PoE+ Switch, 1820 24G PoE+ Switch, and the 1820 48G PoE+ Switch.

- The 1820 8G Switch has 8 auto-sensing 10/100/1000BASE-T RJ-45 ports. Port 1 is a Power over Ethernet Powered Device (PoE PD) port. The switch can be powered by a network connection to port 1 from PoE power sourcing equipment (PSE), such as a PoE switch.
- The 1820 24G Switch has 24 auto-sensing 10/100/1000BASE-T RJ-45 ports and two SFP slots for supported HPE SFP fiber-optic transceivers (ports 25 and 26).
- The 1820 48G Switch has 48 auto-sensing 10/100/1000BASE-T RJ-45 ports and four SFP slots for supported HPE SFP fiber-optic transceivers (ports 49 to 52).
- The 1820 8G PoE+ Switch has 8 auto-sensing 10/100/1000BASE-T RJ-45 ports. The switch supports the IEEE 802.3at standard and is capable of providing 65 watts of PoE power through ports 1-4.
- The 1820 24G PoE+ Switch has 24 auto-sensing 10/100/1000BASE-T RJ-45 ports and two SFP slots for supported HPE SFP fiber-optic transceivers (ports 25 and 26). The switch supports the IEEE 802.3at standard and is capable of providing 185 watts of PoE power through ports 1-12.
- The 1820 48G PoE+ Switch has 48 auto-sensing 10/100/1000BASE-T RJ-45 ports and four SFP slots for supported HPE SFP fiber-optic transceivers (ports 49 to 52). The switch supports the IEEE 802.3at standard and is capable of providing 370 watts of PoE power through ports 1-24.

These switches can be directly connected to computers, printers, and servers to provide dedicated bandwidth to those devices, and you can build a switched network infrastructure by connecting the switch to hubs, other switches, or routers. In addition, these switches offer network management capabilities.

Switch Hardware Features

HP 1820-8G Switch (J9979A)

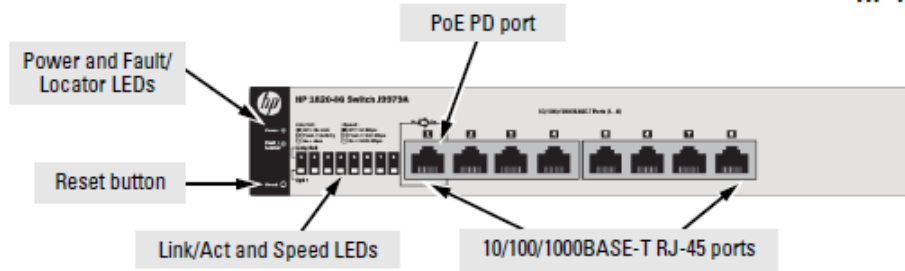

HP 1820-24G Switch (J9980A)

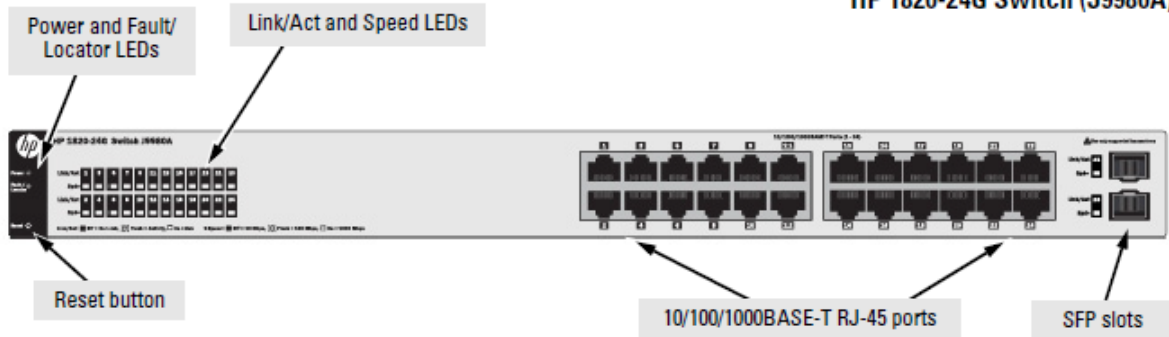

HP 1820-48G Switch (J9981A)

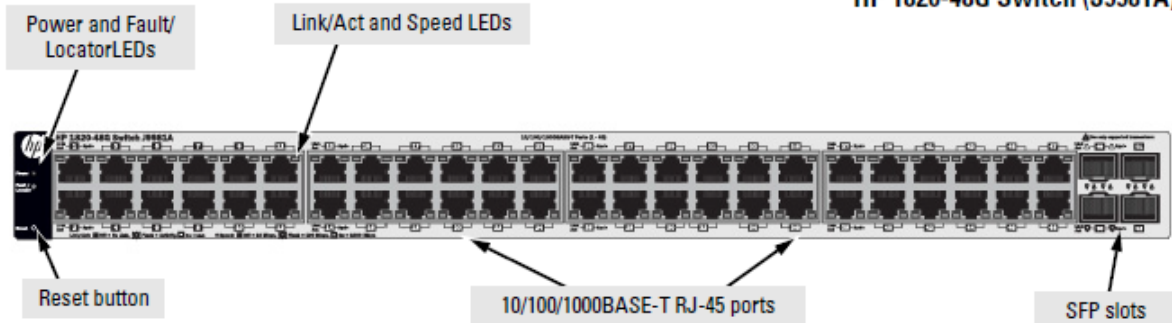

HP 1820-8G-PoE+ (65W) Switch (J9982A)

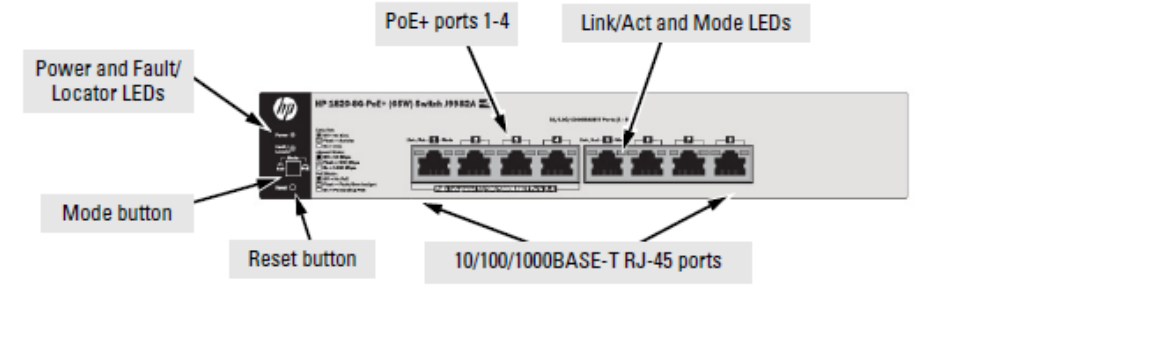

HP 1820-24G-PoE+ (185W) Switch (J9983A)

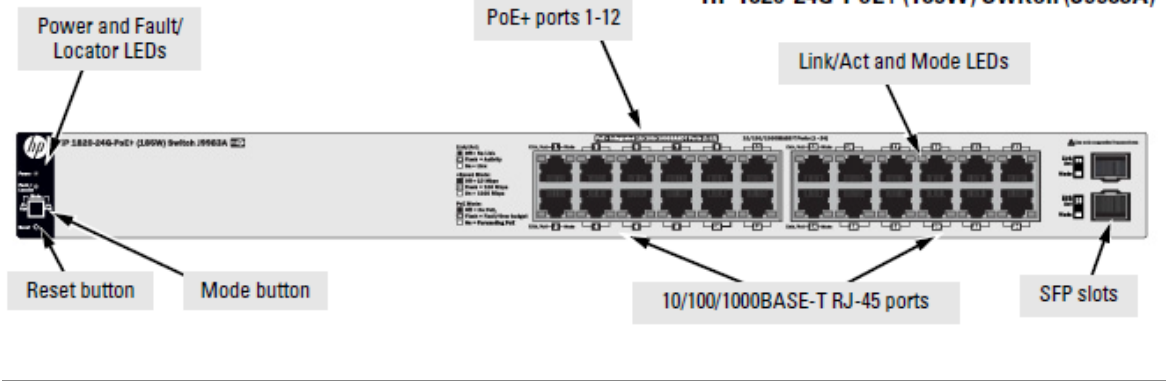

HP 1820-48G-PoE+ (370W) Switch (J9984A)

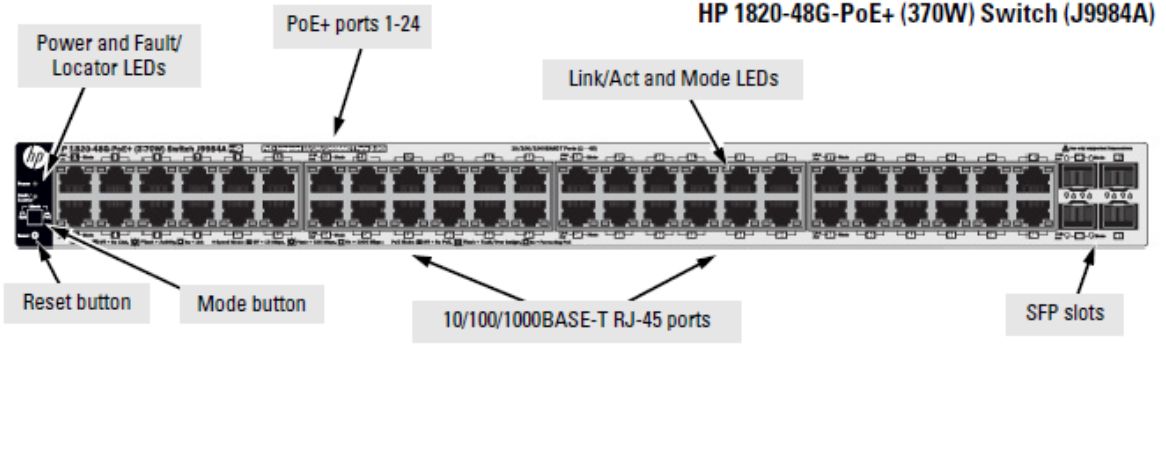

Network Ports

- Auto-sensing 10/100/1000BASE-T ports.
All these ports have the “Auto-MDIX” feature, which means that you can use either straight-through or crossover twisted-pair cables to connect any network devices to the switch.
- Power-over-Ethernet or PoE ports.
The 1820 PoE+ switches support the IEEE 802.3at standard, which allows IP telephones, wireless LAN Access Points, and other appliances to receive power as well as data over existing LAN cabling. For further information regarding PoE power, see the *HPE Power over Ethernet (PoE/PoE+) Planning and Implementation Guide*, which is on the Hewlett Packard Enterprise Web site at www.hpe.com/support/hpesc.
- PoE PD port (1820 8G Switch only).
A network connection to the PoE PD port from a PoE PSE device powers on the switch.
- SFP slots for fiber or copper uplinks.
Using HPE SFPs, these products support optional network connectivity with the following speeds and technologies:

			Transceiver Form-Factor and Connector ¹
Speed	Technology	Cabling	SFP Connector
100 Mbps	100-FX	Fiber (multimode)	LC
1 Gbps	1000-T	Copper (twisted-pair)	RJ-45
	1000-SX	Fiber (multimode)	LC
	1000-LX	Fiber (multimode or single mode)	LC

¹ For supported transceivers, visit www.hpe.com/support/hpesc.

- In the first textbox, type **J4858** (for 100-Mb and Gigabit information).
- Select any of the products that display, then click **Show selected items**.
- Select **Support Center**. Then click **Manuals** and find the **Transceiver Support Matrix**.

For technical details of cabling and technology, see “[Cabling and Technology Information Specifications](#)” (page 36).

LEDs

The front panel of the switch provides status LEDs for system monitoring. The following table details the functions of the various indicators.

LED	State	Meaning
Power (green)	On	The switch is receiving power.
	Blinking*	(1820 8G only) Power is available on the PoE In port (Port 1).
	Off	The switch is NOT receiving power.
Fault/Locator (orange)	On	On briefly after the switch is powered on or reset, at the beginning of switch self test. If the LED remains on, it indicates a detected hardware failure during the self test.
	Blinking**	A fault has occurred on the switch or one of the switch ports. The Link LED for the port with the fault will blink simultaneously.
	Blinking***	The LED is used to locate a specific switch in an area full of switches. The LED blinks for 30 minutes when activated through the switch software.
	Off	The normal state; indicates that there are no fault conditions on the switch.
Link/Act (green)	On	The port is enabled and receiving a link indication from the connected device.
	Off	One of these condition exists: <ul style="list-style-type: none"> no active network cable is connected to the port the port is not receiving link beat or sufficient light Green Mode has been enabled.
	Blinking	Indicates that there is network activity on the port. If the Link/Act LED is blinking simultaneously with the Fault/Locator LED, it indicates a fault on the port. The blinking behavior (1 second on, 1 second off) is the same as the Fault/Locator LED.
SpdMode - Spd‡ (green)	On	Indicates the port is operating at 1000 Mbps.
	Flashing	Indicates the port is operating at 100 Mbps.
	Off	Indicates the port is operating at 10 Mbps.
Mode - PoE‡ (green)	On	Indicates the Port LEDs are lit for ports that are providing PoE power to the connected device.
	Blinking**	There is an oversubscription condition (not enough PoE power available) or the port has experienced a fault condition for PoE delivery.
<p>* The blinking behavior is a 6 second on/off cycle; 5 seconds on, 1 second off.</p> <p>** The blinking behavior is a 2 second on/off cycle; 1 second on, 1 second off.</p> <p>*** The blinking behavior is a 4 second on/off cycle; 3 seconds on, 1 second off.</p> <p>‡ (1820 PoE+ switches only) Press the Mode button in for PoE mode, leave the Mode button out for Spd mode.</p>		

Mode Button

The 1820 PoE+ switches have one Mode LED per port. The Mode LED shows either the port speed or the PoE status. In PoE mode, it shows whether the port is configured to provide PoE power. The operation of the Mode LED is controlled by the Mode select button. Press the Mode button in to select the PoE mode, or leave the button in its out position for Spd (speed) mode.

Reset Button

The Reset button is used to restore Factory Default settings, or reset the switch while it is powered on.

- **Resetting the Switch** — Press and release the button. This action clears any temporary error conditions that may have occurred and executes the switch self test.
- **Restoring Factory Default Configuration** — Press and hold down for over 5 seconds, the switch will then complete its self test and begin operating with its configuration restored to the factory default settings. Any configuration changes you may have made through the web browser interface are removed.

Power Connector

The 1820 24G, 1820 24G-PoE+, 1820 48G, and 1820 48G-PoE+ Switches do not have a power switch, they are powered on when connected to an active AC power source. The switches automatically adjust to any voltage between 100-127 and 200-240 volts and either 50 or 60 Hz. There are no voltage range settings required.

The 1820 8G and 1820 8G PoE+ Switches do not have a power switch, they are powered on when the external AC/DC power adapter is connected to the switch and to a power source. The external AC/DC power adapter supplies 12 volts DC to the switch and automatically adjusts to any AC voltage between 100-240 volts and either 50 or 60 Hz. No voltage range settings are required.

The 1820 8G Switch can also be powered on by a PoE PD connection to Port 1.

Switch Features

The features of the 1820 Switches include:

- 8, 24, or 48 auto-sensing 10/100/1000BASE-T RJ-45 ports.
- 2 or 4 SFP slots for HPE SFP transceivers (1820 24G, 1820 24G-PoE+, 1820 48G, and 1820 48G-PoE+ Switches only)
- plug-and-play networking—all ports are enabled—just connect the network cables to active network devices and your switched network is operational.
- IEEE 802.3ab Auto MDI /MDI-X on all twisted-pair ports, meaning that all connections can be made using straight-through twisted-pair cables. Cross-over cables are not required, although they will also work. The pin operation of each port is automatically adjusted for the attached device: if the switch detects that a 10/100/1000 Mbps switch or hub is connected to the port, it configures the port as MDI; if the switch detects that a 10/100/1000 Mbps end-node device is connected to the port, it configures the port as MDI-X.
- all switches support IEEE 802.3az Energy Efficient Ethernet (EEE) features that reduce power consumption when connected with EEE-compliant client devices.
- automatic learning of MAC addresses in each switch's 8K-address (8- and 24-port switches) or 16K-address (48-port switches) forwarding table.
- automatically negotiated full-duplex operation for all 10/100/1000BASE-T RJ-45 ports when connected to other auto-negotiating devices
- easy management of the switch through several available interfaces:
 - Web browser interface — an easy to use built-in graphical interface that can be accessed from common Web browsers.
 - Intelligent Management Center (iMC) — allows network administrators to discover and map the switches within their network and launch the built-in graphical interface from within iMC to configure the switches.

- support for up to 64 IEEE 802.1Q-compliant VLANs so you can divide the attached end nodes into logical groupings that fit your business needs.
- support for up to 16 trunks (48-port switches) so you can assign physical links to one logical link (trunk) that functions as a single, higher-speed link providing dramatically increased bandwidth.
- support for many advanced features to enhance network performance—for a description, see the *Management and Configuration Guide*.
- download of new switch software for product bug fixes.

2 Installing the Switch

The 1820 Switches are easy to install. They come with an accessory kit that includes the brackets for mounting the switches in a standard 19-inch telco rack, in an equipment cabinet, and with rubber feet that can be attached so the switches can be securely located on a horizontal surface. The brackets are designed to allow mounting of the switches in a variety of locations and orientations. This chapter shows how to install the switches.

Included Parts

The following components ship with an 1820 Switch:

Documentation kit

- Quick Setup Guide
- Safety and Regulatory information
- Software License, Warranty, and Support information
- Accessory kits:

1820 8G and 1820 8G PoE+ Switch	
<p>Kit number 5066-2232</p> <ul style="list-style-type: none"> • two rack mounting brackets • eight 8-mm M4 screws to attach the mounting brackets to the switch • four 5/8-inch number 12-24 screws to attach the switch to a rack • four rubber feet 	<p>Kit number 5066-0621</p> <ul style="list-style-type: none"> • three 3/4" (20-mm M4) screws for wall and under-table mounting • three wall anchors • cable tie for power cord
1820 24G, 1820 24G-PoE+, and 1820 48G Switch	1820-48G-PoE+ Switch
<p>Kit number 5069-6535</p> <ul style="list-style-type: none"> • two wall/table mounting brackets • eight 8-mm M4 screws to attach the mounting brackets to the switch • four 5/8-inch number 12-24 screws to attach the switch to a rack • four rubber feet 	<p>Kit number 5069-5705</p> <ul style="list-style-type: none"> • two rack mounting brackets • eight 8-mm M4 screws to attach the mounting brackets to the switch • four 5/8-inch number 12-24 screws to attach the switch to a rack • four rubber feet <p>Kit number 5092-0769</p> <ul style="list-style-type: none"> • two wall/table mounting brackets

- 1820 24- and 48-port switch AC power cords, one of the following:

Country/Region	HPE 1820 24G, HPE 1820 48G, and HPE 1820 24G-PoE+	HPE 1820 48G-PoE+ ¹
Argentina	8120-6869	8120-8375
Australia/New Zealand	8121-0834	8121-0857
Brazil	8121-1069	8121-1132
Chile	8120-6980	8120-8389
China	8120-8377	8121-1034
Continental Europe	8120-6802	8120-5336
Denmark	8120-6806	8120-5340
India	8121-0780	8120-5341
Israel	8121-1035	8121-1009
Japan	8120-6804	8120-5342
Switzerland	8120-6807	8120-5339
South Africa	8121-0919	8120-5341
South Korea	8120-6811	8120-5336
Taiwan	8121-0964	8121-0967
Thailand	8121-0673	8121-0671
UK/Hong Kong/Singapore/Malaysia	8120-6809	8120-5334
US/Canada/Mexico	8120-6805	8121-0973

¹ The cord for the 1820 48G-PoE+ Switch supports a higher amperage and uses a C16 connector.

- The 1820 8G external AC/DC power adapters, one of the following:

<ul style="list-style-type: none"> • Universal Inline AC/DC Power Adapter All countries/regions 	5066-1122
<p>Power Cords for Inline AC/DC Power Adapter</p> <ul style="list-style-type: none"> Australia/New Zealand Thailand China India Israel Japan South Africa South Korea Taiwan United Kingdom/Hong Kong/Singapore/Malaysia Brazil Argentina Chile 	<ul style="list-style-type: none"> 8121-0870 8121-0664 8120-8373 8121-0702 8120-6314 8120-6316 8120-6317 8120-6314 8121-0963 8120-8699 8121-1081 8120-8367 8121-0514
<ul style="list-style-type: none"> • Wall Plug-in AC/DC Power Adapters (AC Power cords are not used) 	
<ul style="list-style-type: none"> United States/Canada/Mexico Continental Europe/Denmark/Norway/Sweden/Switzerland/Israel/ Vietnam/Indonesia 	<ul style="list-style-type: none"> 5184-5863 5184-5864

- The 1820 8G PoE+ external AC/DC power adapters and power cords, one of the following:

<ul style="list-style-type: none"> • Universal Inline AC/DC Power Adapter (model PA2) All countries/regions 	5066-2164
<p>Power Cords for Inline AC/DC Power Adapter</p> <p>Australia/New Zealand</p> <p>China</p> <p>Continental Europe</p> <p>Denmark</p> <p>India</p> <p>Israel</p> <p>Japan</p> <p>South Africa</p> <p>South Korea</p> <p>Switzerland</p> <p>Taiwan</p> <p>Thailand</p> <p>United Kingdom/Hong Kong/Singapore/Malaysia</p> <p>United States/Canada/Mexico</p> <p>Brazil</p> <p>Argentina</p> <p>Chile</p>	<p>8121-0834</p> <p>8120-8377</p> <p>8120-6802</p> <p>8120-6806</p> <p>8121-0780</p> <p>8121-1035</p> <p>8120-6804</p> <p>8121-0919</p> <p>8120-6811</p> <p>8120-6807</p> <p>8121-0964</p> <p>8121-0673</p> <p>8120-6809</p> <p>8120-6805</p> <p>8121-1069</p> <p>8120-6869</p> <p>8120-6980</p>

Japan Power Cord Warning

製品には、同梱された電源コードをお使い下さい。
同梱された電源コードは、他の製品では使用出来ません。

Installation Precautions

Follow these precautions when installing the switch.

⚠ WARNING!

- The rack or cabinet should be adequately secured to prevent it from becoming unstable and/or falling over.
Devices installed in a rack or cabinet should be mounted as low as possible, with the heaviest devices at the bottom and progressively lighter devices installed above.
 - When wall mounting, to meet national and international safety requirements, wall mount with the network ports facing up. The side vents cannot be placed up or downward.
-

⚠ CAUTION:

- When installing the switch, the AC outlet should be located near the switch and should be easily accessible in case the switch must be powered off.
 - Ensure that the AC power source circuits are properly grounded.
 - Use only the AC/DC power adapter and power cord (if applicable), supplied with the switch. Use of other adapters or power cords, including those that came with other Hewlett Packard Enterprise Networking products, may result in damage to the equipment.
For those switches that use a power cord, if your installation requires a different power cord than the one supplied with the switch, be sure to use a power cord displaying the mark of the safety agency that defines the regulations for power cords in your country. The mark is your assurance that the power cord can be used safely with the switch.
 - Ensure the switch does not overload the power circuits, wiring, and over-current protection. To determine the possibility of overloading the supply circuits, add together the ampere ratings of all devices installed on the same circuit as the switch and compare the total with the rating limit for the circuit. The maximum ampere ratings are usually printed on the devices near the AC power connectors.
 - Do not install the switch in an environment where the operating ambient temperature might exceed 40°C (104°F). This includes a fully-enclosed rack. Ensure the air flow around the sides and back of the switch is not restricted. Leave at least 7.6 cm (3 inches) for cooling.
 - Ensure all port covers are installed when the port is not in use.
-

Installation Procedure

These steps summarize your switch installation. The rest of this chapter provides details on these steps.

1. **Prepare the installation site** – see “1. Prepare the Installation Site” (page 18). Make sure the physical environment into which you will be installing the switch is properly prepared, including having the correct network cabling ready to connect to the switch and having an appropriate location for the switch. See “1. Prepare the Installation Site” (page 18) for some installation precautions.
2. **Verify the switch passes self test** – see “2. Verify the Switch Passes Self Test” (page 19). Plug the switch into a power source and observe that the LEDs on the switch’s front panel indicate correct switch operation.
3. **Mount the switch** – see “3. Mount the Switch” (page 22). The 1820 24- and 48-port switches can be mounted in a 19-inch telco rack, in an equipment cabinet, on a wall, under a table, or on a horizontal surface. The 1820 8-port switches can be mounted on a wall, under a table, or on a horizontal surface.
4. **Connect power to the switch** – see “4. Connect the Switch to a Power Source” (page 25). Once the switch is mounted, plug it into the main power source.
5. **Connect the network devices** – see “5. Connect the Network Cables” (page 26). Using the appropriate network cables, connect the network devices to the switch ports.
6. **(Optional) Install SFP transceivers** – see “2. Verify the Switch Passes Self Test” (page 19). The 1820 24- and 48-port switches have slots for installing SFP transceivers. Depending on where you install the switch, it may be easier to install the SFPs first. SFPs can be hot swapped—they can be installed or removed while the switch is powered on.

At this point, your switch is fully installed. See the rest of this chapter if you need more detailed information on any of these installation steps.

1. Prepare the Installation Site

Be sure to follow the guidelines below to ensure proper operation when installing the switch into a network:

- Verify that copper and fiber cabling meets the requirements of the “Cabling and Technology Information Specifications” (page 36).
- Protect the switch from radio frequency interference emissions.
- Use electrical surge suppression.
- Use safe connections with no damaged cables, connectors, or shields.

Installation Space Requirements

Switch Orientation	Clearance Requirements
Front	At least 7.6 cm (3 inches) of space for the twisted-pair and fiber-optic cabling.
Back	At least 3.8 cm (1 1/2 inches) of space for the power cord and switch cooling.
Sides	At least 7.6 cm (3 inches) for cooling, except if the switch is installed in an open EIA/TIA rack.

2. Verify the Switch Passes Self Test

Before mounting the switch, verify it is working properly by plugging it into a power source and confirming that it passes self test.

1. For the 1820 24- and 48-port switches, connect the power cord supplied with the switch to the power connector on the back of the switch, and then into a properly grounded electrical outlet.

For the 1820 8-port switches, connect the AC/DC adapter's power cord to the power connector on the back of the switch, and then plug the AC/DC power adapter into a nearby properly grounded electrical outlet.

HP 1820 24- and 48-Port Switches

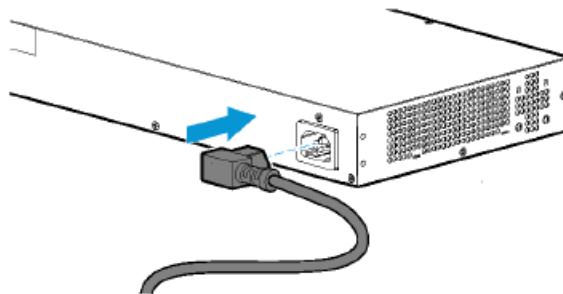

Connect the power cord to the switch and an AC power outlet

HP 1820-8G Switch

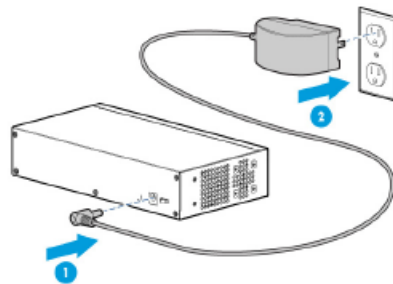

Connect wall plug-in AC/DC power adapter to the switch and an AC power outlet

HP 1820-8G-PoE+ Switch

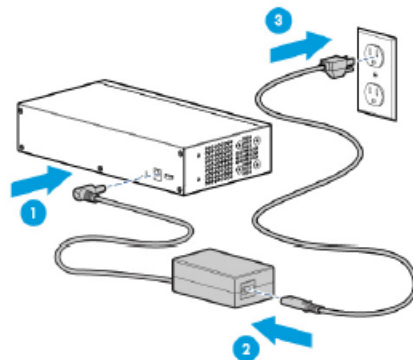

Connect inline AC/DC power adapter to the switch and an AC power outlet

NOTE: The 1820 24- and 48-port switches do not have a power switch. They are powered on when the power cord is connected to the switch and to a power source. For safety, the power outlet should be located near the switch installation.

The switches automatically adjust to any voltage between 100-127 or 200-240 volts and either 50 or 60 Hz. There are no voltage range settings required.

The 1820 8-port switches also do not have a power switch. They are powered on when the external AC/DC power adapter is connected to the switch and the adapter power cord to a power source. The external AC/DC power adapter automatically adjusts to any voltage between 100-240 volts and either 50 or 60 Hz.

2. Check the LEDs on the switch as described below.

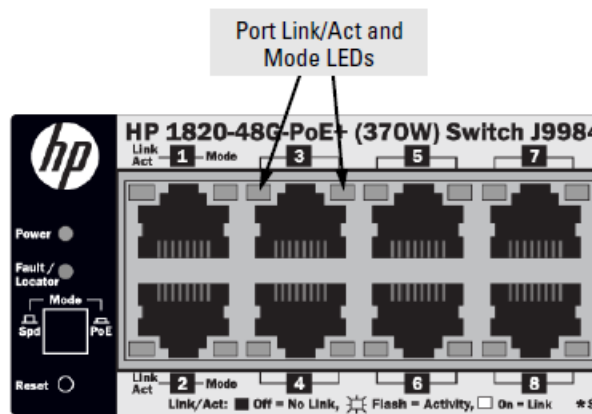
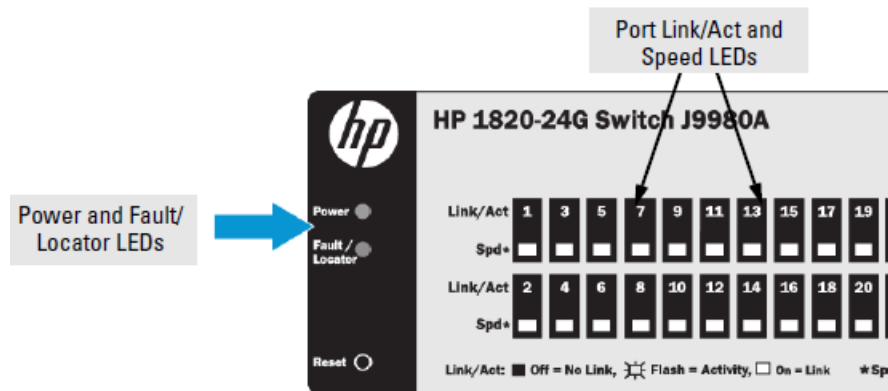

When the switch is powered on, it performs a diagnostic self test.

Self Test LED Behavior:

During the self test:

- Initially, the **Power**, **Fault/Locator**, and all port LEDs turn on.
- After several seconds, the **Power** and **Fault/Locator** LEDs remain on, and the port LEDs turn off. Then each port Link LED is sequentially turned on, then off.
- The **Fault/Locator** LED turns off when the self test completes.

When the self test completes successfully:

- The **Power** LED remains on.
- The **Fault/Locator** LED stays off.
- The port LEDs on the front of the switch go into their normal operational mode:
 - If the ports are connected to active network devices, the **Link/Act** LEDs stay on or may be blinking to indicate port activity. The **Spd** LEDs turn on for 1000 Mbps links, blink for 100 Mbps links, or stay off for 10 Mbps links. On the PoE+ switches, the **Mode** LEDs behave according to the mode selected. In the default mode (**Spd**), the **Mode** LEDs should be on for 1000 Mbps links, blink for 100 Mbps links, or stay off for 10 Mbps links.
 - If the ports are not connected to active network devices, the **Link/Act** and **Spd** LEDs will stay off.

If the LED display is different than what is described above, the self test has not completed correctly. Refer to [“Troubleshooting” \(page 31\)](#) for diagnostic help.

3. Remove power to the switch before mounting.

3. Mount the Switch

The switch can be mounted in these ways:

- on a horizontal surface
- on a wall
- under a table
- in a rack or cabinet

Rack or Cabinet Mounting

The switches are designed to be mounted in any EIA-standard 19-inch telco rack or communication equipment cabinet. Note that the mounting brackets have multiple mounting holes and can be rotated allowing for a wide variety of mounting options.

⚠ WARNING! For safe operation, please read [“Installation Precautions”](#) (page 17) before mounting the switch.

NOTE: The screws supplied with the switch are the correct threading for standard EIA/TIA open 19-inch racks. If you are installing the switch in an equipment cabinet such as a server cabinet, use the clips and screws that came with the cabinet in place of the screws that are supplied with the switch.

Complete the following step 1 to attach brackets to the switch. Then, plan which four holes you will be using in the cabinet and install all four clips. Then proceed to step 2 to install the switch in the cabinet.

1. Use a #1 Phillips (cross-head) screwdriver and attach the mounting brackets to the switch with the included 8-mm M4 screws.

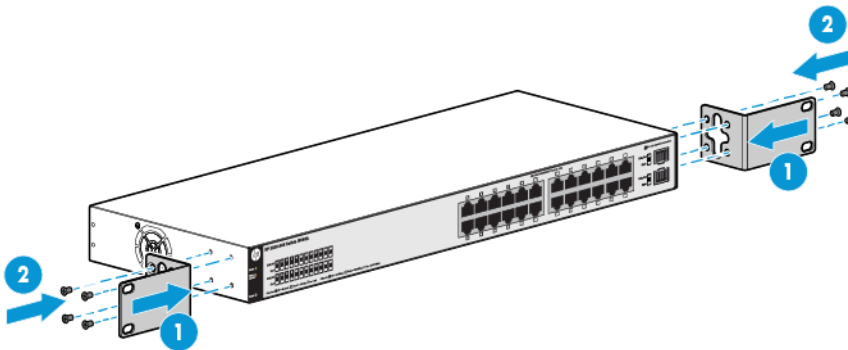

NOTE: The mounting brackets have multiple mounting holes and can be rotated allowing for a wide variety of mounting options. These include mounting the switch so its front face is flush with the face of the rack, as shown in the illustration.

2. Hold the switch with attached brackets in the rack and move it vertically until rack holes line up with the bracket holes, then insert and tighten the four 12-24 screws holding the brackets to the rack.

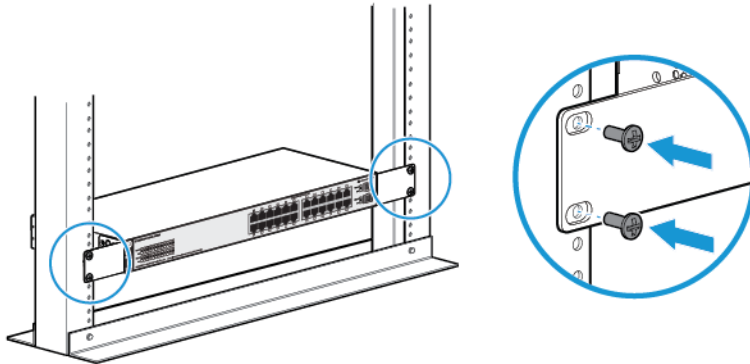

Wall or Under-Table Mounting

You can mount the 1820 24- and 48-port switches on a wall with either the front or rear panel facing up.

- ⚠ WARNING!** For safe operation, please read “[Installation Precautions](#)” (page 17) before mounting the switch.

Wall mount the switch with the network ports facing up or down.

- ⚠ CAUTION:** The switch should be mounted only to a wall or wood surface that is at least 1/2-inch (12.7 mm) plywood or its equivalent.

To mount the 1820 24- and 48-port switches, follow these steps:

1. Use a #1 Phillips (cross-head) screwdriver and attach the mounting brackets to the switch with the included 8-mm M4 screws.
2. Attach the switch to the wall or wood surface with two 5/8-inch number 12 wood screws (not included).

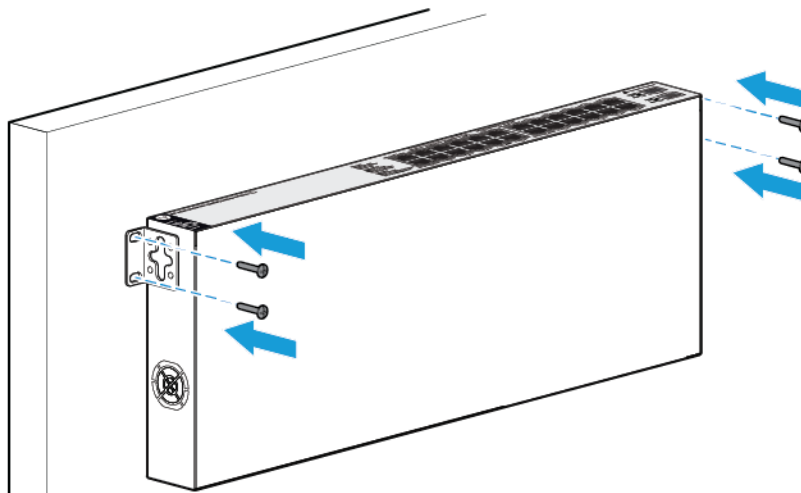

To mount the 1820 8-port switches, follow these steps:

1. In the required location, mark the position for the mounting screws. The hole-to-hole distance is 3.54 inch (90 mm).

2. Use a #1 Phillips (cross-head) screwdriver and two of the included 20-mm M4 tap screws. Set the screw heads approximately 2 mm away from the mounting surface to allow the switch to slide onto the screws.

Wall anchors are included in the accessory kit for use with plastered brick or concrete walls.

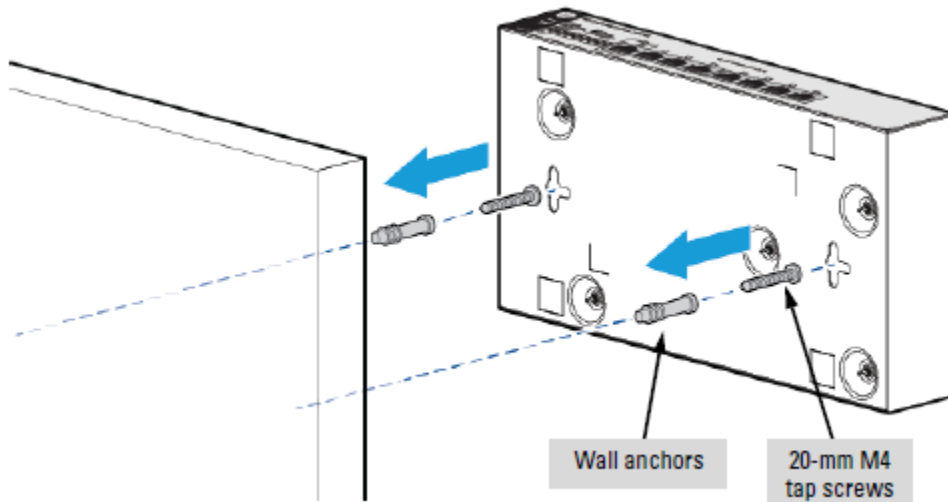

3. For under-table mounting, a third 20-mm M4 tap screw can be placed against one side of the switch to secure it in place.

Horizontal Surface Mounting

Place the switch on a table or other horizontal surface. The switch comes with rubber feet in the accessory kit that can be used to help keep the switch from sliding on the surface.

Attach the rubber feet to the four corners on the bottom of the switch within the embossed angled lines. Use a sturdy surface in an uncluttered area. You may want to secure the networking cables and switch power cord to the table leg or other part of the surface structure to help prevent tripping over the cords.

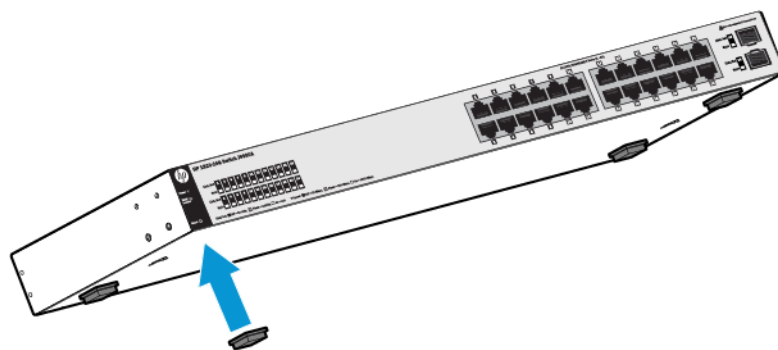

Using a Kensington Security Cable

To prevent unauthorized removal of the switch, you can use a Kensington Slim MicroSaver security cable (not included) to attach the switch to an immovable object.

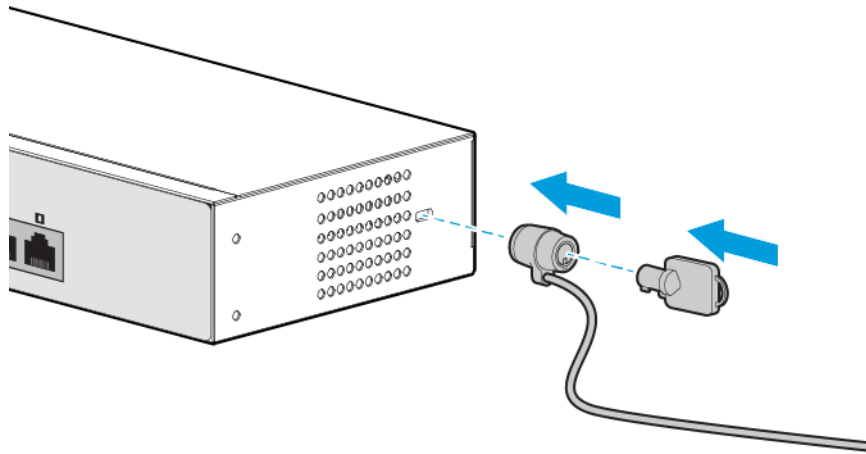

4. Connect the Switch to a Power Source

1. For the 1820 24-port and 48-port switches, plug the included power cord into the switch's power connector and into a nearby AC power source.
For the 1820 8-port switches, plug the AC/DC adapter's power cord into the switch, and then plug the AC/DC power adapter into a nearby AC power source.

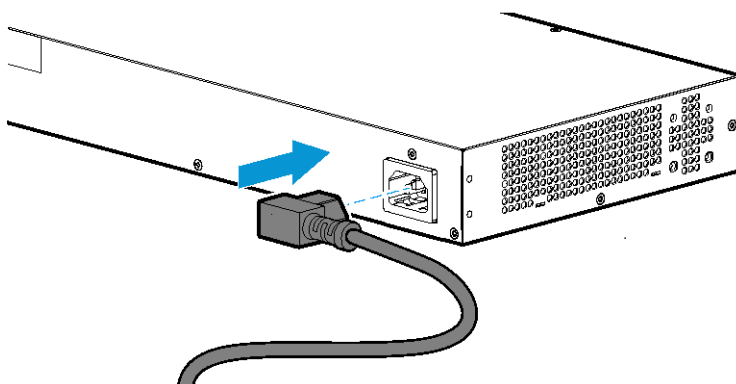

2. Re-check the LEDs during self test. See [“Self Test LED Behavior:”](#).
3. For the 1820 8-port switches, use the included cable tie to secure the power cord to the switch.

5. Connect the Network Cables

Connect the network cables, from the network devices or your patch panels, to the fixed RJ-45 ports on the switch or to any SFP transceivers you have installed in the switch.

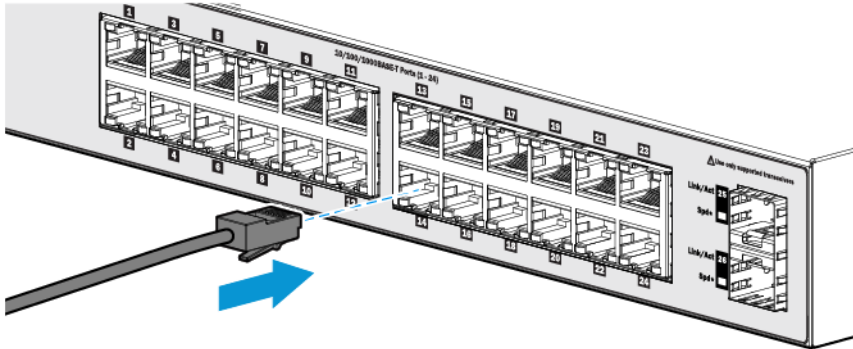

100-ohm unshielded or shielded twisted pair cable:

- Category 3, 4, or 5 for 10 Mbps ports
- Category 5 only for 100 Mbps ports
- Category 5, 5e, or 6 for 1000 Mbps ports

Maximum distance: 100 meters

When a network cable from an active network device is connected to the port, the port LEDs for that port should go on. If the port LEDs do not go on when the network cable is connected to the port, see [“Diagnosing with the LEDs”](#) (page 31).

6. Installing or Removing SFPs

You can install or remove an SFP from an SFP slot without having to power off the switch. Use only HPE SFPs (see table in [“Network Ports”](#) (page 8)).

⚠ CAUTION: Hot swapping transceivers is supported. You can install or remove a transceiver with the switch powered on, a reset will not occur. However, rapid hotswaps are not recommended. Wait a few seconds for the Mode LED to turn on (during initialization), and then turn off.

CAUTION: Use only supported genuine HPE SFPs with your switch. Non-HPE SFPs are not supported, and their use may result in product malfunction. Should you require additional HPE SFPs, contact your Hewlett Packard Enterprise Networking Sales and Service Office or authorized dealer.

NOTE: Ensure the network cable is NOT connected when you install or remove an SFP.

Installing the SFPs:

Remove the protective plastic cover and retain it for later use. Hold the SFP by its sides and gently insert it into any of the slots on the switch until the SFP clicks into place.

⚠ WARNING! The HPE SFPs are Class 1 laser devices. Avoid direct eye exposure to the beam coming from the transmit port.

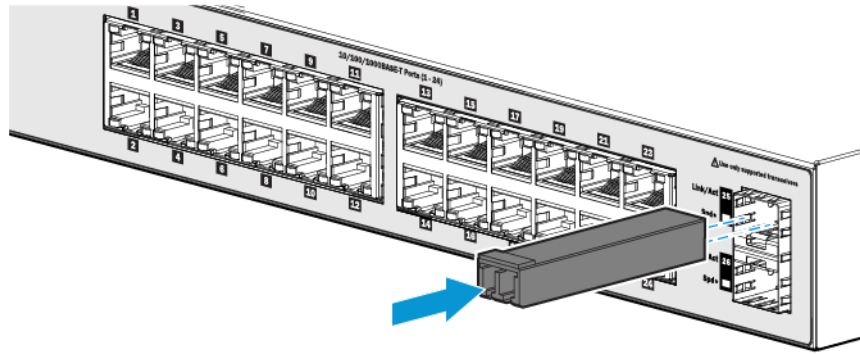

Removing the SFPs

NOTE: You should disconnect the network cable from the SFP before removing it from the switch.

Depending on when you purchased your HPE SFP, it may have either of three different release mechanisms: a plastic tab on the bottom of the SFP, a plastic collar around the SFP, or a wire bail.

To remove the SFPs that have the plastic tab or plastic collar, push the tab or collar toward the switch until you see the SFP release from the switch (you can see it move outward slightly), and then pull it from the slot.

To remove the SFPs that have the wire bail, lower the bail until it is approximately horizontal, and then using the bail, pull the SFP from the slot.

Replace the protective plastic cover on the SFP.

Connecting Cables to SFPs

If you have any SFPs installed in the switch, the type of network connections you will need to use depends on the type of SFPs you have installed. See the table in [“Network Ports” \(page 8\)](#), and appendix A, [“Specifications” \(page 35\)](#), for the SFP cabling information.

For SFP ports, and in general for all the switch ports, when a network cable from an active network device is connected to the port, the port Link LED for that port should go on. If the port Link LED does not go on when the network cable is connected to the port, see [“Diagnosing with the LEDs” \(page 31\)](#) in chapter 4, “Troubleshooting”.

3 Configuring the Switch

Initial Configuration

The 1820 Switch Series can be managed through a Web-browser interface that you can access from any PC or workstation connected to the switch.

To access the Web interface, you must have the switch's Internet Protocol (IP) address. In the factory default configuration, the IP address is automatically acquired from a Dynamic Host Configuration Protocol (DHCP) service that is available on your network or from your Internet Service Provider (ISP). Most routers provide this service. The DHCP service automatically provides a network IP address configuration to devices that request it, such as the 1820 switches.

Many features are configurable on the 1820 Switch Series. Hewlett Packard Enterprise recommends that at minimum, you configure a management password for switch security. Follow these procedures to access the switch's Web interface to perform the switch configuration:

1. Place the switch close to the PC that you will use for configuration. It helps if you can see the front panel of the switch while working from your PC.
2. Connect power to the switch, and then start your PC (if it is not already running) and wait until the switch and PC have finished their start-up sequences.
3. Connect the PC to any port on the switch using a standard Ethernet LAN cable. Verify that there is a link between the switch and PC by checking the LEDs for the network port that you are using. (For more information on LEDs, see [“LEDs” \(page 9\)](#) .)
4. If the switch has access to a DHCP service, it automatically acquires an IP address. Determine the IP address of the switch by examining the client IP address table on your router (see the router documentation for how to get this information), or talk to your ISP representative to get the IP address of the switch.

If a DHCP service is not available in your network, or for some reason the switch does not acquire an IP address from the service, the switch defaults to IP address **192.168.1.1** after 120 seconds of automatically attempting to acquire an IP address.

NOTE: Alternatively, if you cannot determine the switch's IP address, you can force it to use the 192.168.1.1 address by first disconnecting the switch from any router or internet connection and then unplugging and reconnecting power to it.

To communicate with the switch using the 192.168.1.1 address, see [“Using the 192.168.1.1 IP Address” \(page 30\)](#) before continuing these steps.

5. From the PC connected to the switch, open a Web-browser session and enter the switch's IP address as the URL. This opens the login screen for the switch's Web browser interface from which you perform the next steps.
6. Enter the default username “admin” and click **Login** to start a switch Web-browser interface session. By default, there is no password.
7. To configure a password on the switch Web interface, click **Maintenance > Password Manager** and enter the **Current Password**. Define a **New Password** and reenter it in the **Confirm New Password** field. Passwords can be up to 64 alphanumeric and special characters in length, and are case sensitive.
8. Click **Apply** to implement the new password, and then click **Save Configuration** at the top of the browser configuration screen to save your settings and retain them when the switch is rebooted.

See the *HPE 1820 Switch Series Management and Configuration Guide* for more switch configuration information.

NOTE: If you cannot remember the switch's IP address or password, you can restore the factory default settings by following the procedure described in the “[Troubleshooting](#)” (page 31) section.

Using the 192.168.1.1 IP Address

If the switch does not acquire an IP address via the DHCP request, it defaults to the following configuration:

Parameter	Factory Default Setting
Password	<blank>
IP address	192.168.1.1
Subnet mask	255.255.255.0
Default gateway	not set

To communicate with the switch using the 192.168.1.1 address:

1. Connect a PC directly to any of the switch's network ports using a standard Ethernet cable.
2. Configure the PC's IP Address and Subnet Mask to allow it to communicate with the switch through your PC's Web browser.

For example, for Windows 7, follow these steps:

- a. Click **Start**, and then click **Control Panel**. In the Control Panel, click **Network and Internet** and then **Network and Sharing Center**.
- b. Click **Local Area Connection**, and then click **Properties**. If you are prompted for an administrator password or for a confirmation, type the password or provide confirmation.
- c. Click **Internet Protocol Version 4 (TCP/IPv4)** and then click **Properties**.

NOTE: Record your PC's current IP settings to be able to restore them later, if needed.

3. Click **Use the following IP address**, and then, in the **IP address** and **Subnet mask** fields, type the IP address settings:
 - a. For **IP address**, enter an IP address in the same range as the switch's IP address, for example, enter **192.168.1.12**.
 - b. For **Subnet mask**, enter **255.255.255.0**, then click **OK**.
 - c. Click **Close** (or **OK**) to close the **Local Area Connection Properties** screen.
4. Open the Web browser on the PC, and enter the switch address, **http://192.168.1.1** to access the switch's Web interface. Go back to step 6 in “[Initial Configuration](#)” (page 29) to configure the switch.

Where to Go From Here

For more information on the Web browser interface and all the features that can be configured on the 1820 Switch Series, see the *HPE 1820 Switch Series Management and Configuration Guide*, which is available on the Hewlett Packard Enterprise Web site, <http://www.hpe.com/support/hpesc>.

4 Troubleshooting

This section describes how to troubleshoot the switch. For more information, see the chapter “Troubleshooting” in the *HPE 1820 Switch Series Management and Configuration Guide*, available on the Hewlett Packard Enterprise Web site, <http://www.hpe.com/support/hpesc>.

This chapter describes the following:

- basic troubleshooting tips – “Basic Troubleshooting Tips” (page 31)
- diagnosing with the LEDs – “Diagnosing with the LEDs” (page 31)
- forgotten IP address or password – “Restoring to Factory Defaults” (page 33)
- testing the switch by resetting it – “Testing the Switch by Resetting It” (page 33)
- Hewlett Packard Enterprise Customer Support Services – “Accessing Hewlett Packard Enterprise Support” (page 34)

Basic Troubleshooting Tips

Common problems and their solutions are listed in the following table.

Problem	Resolution
Switch fails Power-On Self Test (POST)	Troubleshoot using the LEDs. See “Diagnosing with the LEDs” (page 31)
Link light does not light when a cable is connected.	Look for loose or obviously faulty connections. If they appear to be OK, make sure the connections are snug. If that does not correct the problem, try a different cable.

Diagnosing with the LEDs

The first section shows LED patterns on the switch that indicate problem conditions for general switch operation troubleshooting.

The second section shows LED patterns that indicate problem conditions for PoE troubleshooting.

LED patterns for General Switch Troubleshooting

1. Check in the table below for the LED pattern you see on your switch.
2. Refer to the corresponding diagnostic tip on the next few pages.

LED Pattern Indicating Problems			See Diagnostic Tips (page 32)
Power	Fault	Port LED	
Off with power cord plugged in	*	*	❶
On	Prolonged On	*	❷
On	Blinking†	Blinking†	❸
On	Off	Off with cable connected	❹

* This LED is not important for the diagnosis.
† The blinking behavior is an on/off cycle once every 1.6 seconds, approximately.

Diagnostic Tips

Tip	Problem	Solution
❶	The switch is not plugged into an active AC power source, the switch's power adapter may have failed, or Port 1 is not receiving power from a PoE power sourcing equipment (PSE).	<ol style="list-style-type: none"> 1. Verify the power cord is plugged into an active power source and to the switch. Make sure these connections are snug. 2. Verify the PoE PSE is supplying sufficient power from a port that has an appropriate PoE priority. 3. Try power cycling the switch by unplugging and plugging the power cord back in. 4. If the Power LED is still not on, verify that the AC power source works by plugging another device into the outlet. Or try plugging the switch into a different outlet or try a different power cord. <p>If the power source and power cord are OK and this condition persists, the switch power supply may have failed. Call your Hewlett Packard Enterprise-authorized network reseller, or use the electronic support services from Hewlett Packard Enterprise to get assistance.</p>
❷	A switch hardware failure has occurred. All the LEDs will stay on indefinitely.	Try power cycling the switch. If the fault indication reoccurs, the switch may have failed. Call your Hewlett Packard Enterprise-authorized network reseller, or use the electronic support services from Hewlett Packard Enterprise to get assistance.
❸	The network port for which the Link LED is blinking has experienced a self test or initialization failure.	<p>Try power cycling the switch. If the fault indication reoccurs, the switch port may have failed. To confirm, try a different port that appears to be good. Call your Hewlett Packard Enterprise-authorized network reseller, or use the electronic support services from Hewlett Packard Enterprise to get assistance.</p> <p>If the port is an SFP, verify that it is one of the SFPs supported by the switch. Unsupported SFPs will be identified with this fault condition. The supported SFPs are listed in Chapter 1, "Switch Overview" on "Network Ports" (page 8). The SFPs are also tested when they are "hot-swapped"— installed or changed while the switch is powered on.</p> <p>To verify that the port has failed, try removing and reinstalling the SFP without having to power off the switch. If the port fault indication reoccurs, you will have to replace the SFP.</p>
❹	The network connection is not working properly.	<p>Try the following procedures:</p> <ul style="list-style-type: none"> • For the indicated port, verify that both ends of the cabling, at the switch and the connected device, are secure. • Verify the connected device and switch are both powered on and operating correctly. • Verify that the connected devices comply with the appropriate IEEE 802.3 standard, including transmission of the Link signal. • If the other procedures do not resolve the problem, try using a different port or a different cable.

LED Patterns for PoE Troubleshooting

Press the LED Mode button to put the switch into PoE mode and the port Mode LEDs will show which ports are experiencing the problem. The following tables identify the specific problems that are shown by the LEDs.

1. Check in the table for the LED pattern you see on your switch.
2. Refer to the corresponding diagnostic tip.

LED Pattern Indicating Problems			Diagnostic Tips (see table below)
Fault	Port Link	Port Mode(PoE)	
Off	Fast Blinking Green	Fast Blinking Green	❶
Fast Blinking	Fast Blinking Green	Fast Blinking Green	❷

Diagnostic Tips:

Tip	Problem	Solution
❶	PoE oversubscription condition. All available PoE power is already taken by higher-priority ports.	If possible add additional PoE power, or redefine port priorities.
❷	PoE hardware fault. A switch hardware component that is involved with PoE power delivery has failed.	The switch must be replaced.

Testing the Switch by Resetting It

If you believe the switch is not operating correctly, you can reset the switch to test its circuitry and operating code. To reset the switch, unplug and plug in the power cord (power cycling).

Power cycling the switch will cause the switch to perform its power-on self test. Resetting the switch can also be invoked from the Web interface.

Restoring to Factory Defaults

If you forget the switch IP address or password, you can restore the factory default configuration by pressing the Reset button.

To execute the factory default reset on the switch, perform these steps:

1. Using a small, thin tool with blunt ends (such as a paper clip), press the Reset button on the front of the switch.
2. Continue to press the Reset button until the Fault LED light begins to flash.
3. Release the Reset button.

The switch will then complete its self test and begin operating with its configuration restored to the factory default settings.

After completing this procedure, there will be no password, the IP address will be returned to the default 192.168.1.1, and all configuration settings will be returned to factory defaults.

Accessing Hewlett Packard Enterprise Support

- For live assistance, go to the Contact Hewlett Packard Enterprise Worldwide website:
www.hpe.com/assistance
- To access documentation and support services, go to the Hewlett Packard Enterprise Support Center website:
www.hpe.com/support/hpesc

Information to collect

- Technical support registration number (if applicable)
- Product name, model or version, and serial number
- Operating system name and version
- Firmware version
- Error messages
- Product-specific reports and logs
- Add-on products or components
- Third-party products or components

A Specifications

Switch Specifications

Physical

	Width	Depth	Height	Weight
1820 8G (J9979A)	25.4 cm (10.0 in)	15.95 cm (6.28 in)	4.4 cm (1.73 in)	0.8 kg (1.8 lb)
1820 24G (J9980A)	44.25 cm (17.42 in)	24.61 cm (9.69 in)	4.4 cm (1.73 in)	2.7 kg (6.0 lb)
1820 48G (J9981A)	44.25 cm (17.42 in)	24.61 cm (9.69 in)	4.4 cm (1.73 in)	3.3 kg (7.3 lb)
1820 8G PoE+ (J9982A)	25.40 cm (10.0 in)	15.95 cm (6.28 in)	4.4 cm (1.73 in)	0.9 kg (2.0 lb)
1820 24G PoE+ (J9983A)	44.25 cm (17.42 in)	24.61 cm (9.69 in)	4.4 cm (1.73 in)	3.3 kg (7.3 lb)
1820 48G PoE+ (J9984A)	44.25 cm (17.42 in)	32.26 cm (12.7 in)	4.4 cm (1.73 in)	4.4 kg (9.7 lb)

Electrical

	AC voltage	Maximum current	Frequency range
1820 8G (J9979A) ^{1,3}	100-240 volts	0.2 A	50/60 Hz
1820 24G (J9980A) ²	100-127 volts200-240 volts	0.5 A / 0.3 A	50/60 Hz
1820 48G (J9981A) ²	100-127 volts200-240 volts	0.7 A / 0.4 A	50/60 Hz
1820 8G PoE+ (J9982A) ¹	100-240 volts	0.9 A	50/60 Hz
1820 24G PoE+ (J9983A) ²	100-127 volts200-240 volts	2.6 A / 1.3 A	50/60 Hz
1820 48G PoE+ (J9984A) ²	100-127 volts200-240 volts	5 A / 2.5 A	50/60 Hz

¹ Requires a connection to an external power adapter. The adapter automatically adjusts to any voltage between 100 and 240 volts and either 50 or 60 Hz.

² The switch automatically adjusts to any voltage between 100-127 or 200-240 volts and either 50 or 60 Hz.

³ The switch can also be powered by a PoE PD connection to Port 1. Port 1 is an IEEE 802.3af Compatible PD (PoE Powered Device) - Class 3.

Environmental

	Operating	Non-Operating
Temperature	0°C to 40°C (32°F to 104°F)	-40°C to 70°C (-40°F to 158°F)
Relative humidity(non-condensing)	15% to 95% at 40°C (104°F)	15% to 95% at 65°C (149°F)
Maximum altitude	3.0 Km (10,000 ft)*	4.57 Km (15,000 ft)

* The operating maximum altitude should not exceed that of any accessory being connected to any 1820 Switch.

Acoustics

	Noise Emmission
1820 24G-PoE+(J9983A)	Geraeuschemission LpA=37.9 dB am fiktiven Arbeitsplatz nach DIN 45635 T.19 Noise Emission LpA=37.9 dB at virtual workspace according to DIN 45635 T.19
1820 48G-PoE+(J9984A)	Geraeuschemission LpA=45 dB am fiktiven Arbeitsplatz nach DIN 45635 T.19 Noise Emission LpA=45 dB at virtual workspace according to DIN 45635 T.19

1820 8G, 1820 24G, 1820 48G, and 1820 8G PoE+ Switches:

Power: 0 dB (no fans)

Safety

Complies with:

- EN60950-1:2006+A11:2009+A1:2010+A12:2011 / IEC60950-1:2005; Am1:2009;
- CSA22.2 No. 60950-1-07 2nd; UL60950-1 2nd
- EN 60825-1:2007 / IEC 60825-1:2007 Class 1

Standards

		Laser safety information	
Technology	Compatible with these IEEE standards	EN/IEC standard compliance	SFP Lasers
10-T 100-TX 1000-T	IEEE 802.3 10BASE-T IEEE 802.3u 100BASE-TX IEEE 802.3ab 1000BASE-T		
100-FX	IEEE 802.3u 100BASE-FX	EN/IEC 60825	Class 1 Laser Product Laser Klasse 1
1000-SX	IEEE 802.3z 1000BASE-SX	EN/IEC 60825	Class 1 Laser Product Laser Klasse 1
1000-LX	IEEE 802.3z 1000BASE-LX	EN/IEC 60825	Class 1 Laser Product Laser Klasse 1

Cabling and Technology Information Specifications

Twisted-pair copper	10 Mbps Operation	Category 3, 4 or 5, 100-ohm unshielded twisted-pair (UTP) or shielded twisted-pair (STP) cable, complying with IEEE 802.3 10BASE-T specifications.
	100 Mbps Operation	Category 5, 100-ohm UTP or STP cable, complying with IEEE 802.3u 100BASE-TX specifications.
	1000 Mbps Operation	Category 5, 100-ohm 4-pair UTP or STP cable, complying with IEEE 802.3ab 1000BASE-T specifications—Category 5e or better is recommended. See note on 1000BASE-T Cable Requirements below.

Multimode fiber		62.5/125 μm or 50/125 μm (core/cladding) diameter, low metal content, graded index fiber-optic cables, complying with the ITU-T G.651 and ISO/IEC 793-2 Type A1b or A1a standards respectively. ¹
Single mode fiber		9/125 μm (core/cladding) diameter, low metal content fiber-optic cables, complying with the ITU-T G.652 and ISO/IEC 793-2 Type B1 standards.
¹ A mode conditioning patch cord may be needed for some Gigabit-LX installations. See “ Mode Conditioning Patch Cord ” (page 37) for more information.		

Note on 1000BASE-T Cable Requirements. The Category 5 networking cables that work for 100BASE-TX connections should also work for 1000BASE-T, as long as all four-pairs are connected. But, for the most robust connections, you should use cabling that complies with the Category 5e specifications, as described in Addendum 5 to the TIA-568-A standard (ANSI/TIA/EIA-568-A-5).

Because of the increased speed provided by 1000BASE-T (Gigabit-T), network cable quality is more important than for either 10BASE-T or 100BASE-TX. Cabling plants being used to carry 1000BASE-T networking must comply with the IEEE 802.3ab standards. In particular, the cabling must pass tests for Attenuation, Near-End Crosstalk (NEXT), and Far-End Crosstalk (FEXT). Additionally, unlike the cables for 100BASE-TX, the 1000BASE-T cables must pass tests for Equal-Level Far-End Crosstalk (ELFEXT) and Return Loss.

When testing your cabling, be sure to include the patch cables that connect the switch and other end devices to the patch panels on your site. The patch cables are frequently overlooked when testing cable and they must also comply with the cabling standards.

Technology Distance Specifications

Technology	Supported cable type	Multimode fiber modal bandwidth	Supported distances
100-FX	multimode fiber	any	up to 2,000 meters
1000-T	twisted-pair copper	N/A	up to 100 meters
1000-SX	multimode fiber	160 MHz*km 200 MHz*km 400 MHz*km 500 MHz*km	2 - 220 meters 2 - 275 meters 2 - 500 meters 2 - 550 meters
1000-LX	multimode fiber	400 MHz*km 500 MHz*km	2 - 550 meters 2 - 550 meters
	single mode fiber	N/A	2 - 10,000 meters

Mode Conditioning Patch Cord

The following information applies to installations in which multimode fiber-optic cables are connected to a Gigabit-LX port. Multimode cable has a design characteristic called “Differential Mode Delay”, which requires the transmission signals be “conditioned” to compensate for the cable design and thus prevent resulting transmission errors.

Under certain circumstances, depending on the cable used and the lengths of the cable runs, an external Mode Conditioning Patch Cord may need to be installed between the Gigabit-LX transmitting device and the multimode network cable to provide the transmission conditioning. If you experience a high number of transmission errors on those ports, usually CRC or FCS errors, you may need to install one of these patch cords between the fiber-optic port in your switch and your multimode fiber-optic network cabling, at both ends of the network link.

The patch cord consists of a short length of single mode fiber cable coupled to graded-index multimode fiber cable on the transmit side, and only multimode cable on the receive side. The section of single mode fiber is connected in such a way that it minimizes the effects of the differential mode delay in the multimode cable.

NOTE: Most of the time, if you are using good quality graded-index multimode fiber cable that adheres to the standards listed in this appendix, there should not be a need to use mode conditioning patch cords in your network. This is especially true if the fiber runs in your network are relatively short.

Installing the Patch Cord

As shown in the illustration below, connect the patch cord to the transceiver with the section of single mode fiber plugged in to the Tx (transmit) port. Then, connect the other end of the patch cord to your network cabling patch panel, or directly to the network multimode fiber.

If you connect the patch cord directly to the network cabling, you may need to install a female-to-female adapter to allow the cables to be connected together.

Figure 1 Example: Connecting a Mode Conditioning Patch Cord for Gigabit-LX

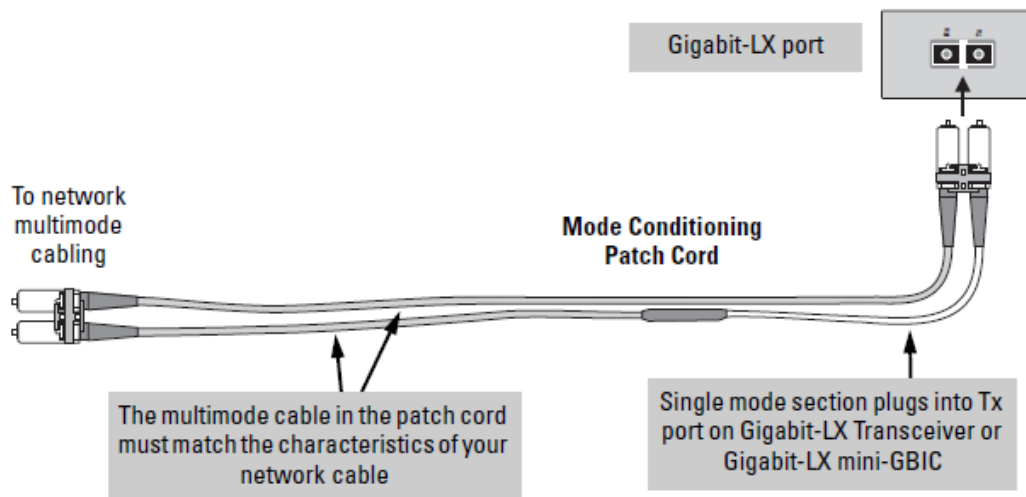

Make sure you purchase a patch cord that has appropriate connectors on each end, and has multimode fibers that match the characteristics of the multimode fiber in your network. Most important, the core diameter of the multimode patch cord must match the core diameter of the multimode cable infrastructure (either 50 or 62.5 microns).

Twisted-Pair Cable/Connector Pin-Outs

The Auto-MDIX Feature:

In the default configuration, “Auto”, the fixed 10/100/1000BASE-T ports on the switches all automatically detect the type of port on the connected device and operate as either an MDI or MDI-X port, whichever is appropriate. So for any connection, a straight-through twisted-pair cable can be used—you *no longer have to use crossover cables*, although crossover cables can also be used for any of the connections. (The 10/100/1000-T ports support the IEEE 802.3ab standard, which includes the “Auto-MDIX” feature.)

If you connect a switch twisted-pair port to another switch or hub, which typically have MDI-X ports, the switch port automatically operates as an MDI port. If you connect it to an end node, such as a server or PC, which typically have MDI ports, the switch port operates as an MDI-X port. In all cases, you can use standard straight-through cables or crossover cables.

If you happen to use a correctly wired crossover cable, though, the switch will still be able to automatically detect the MDI/MDI-X operation and link correctly to the connected device.

NOTE: Using Fixed Configurations. If the port configuration is changed to any of the fixed configurations though, for example 100 Mbps/full duplex, the port operates as MDI-X only and the correct cable type must be used: for connections to MDI ports, such as end nodes, use a straight-through cable; for connections to MDI-X ports, such as on hubs and other switches, use a crossover cable.

Other Wiring Rules:

- All twisted-pair wires used for 10 Mbps, and 100 Mbps operation must be twisted through the entire length of the cable. The wiring sequence must conform to EIA/TIA 568-B (not USOC). See “Twisted-Pair Cable Pin Assignments” later in this appendix for a listing of the signals used on each pin.
- For 1000BASE-T connections, all four pairs of wires in the cable must be available for data transmission.
- For 10 Mbps connections to the ports, you can use Category 3, 4, or 5 unshielded twisted-pair cable, as supported by the IEEE 802.3 Type 10BASE-T standard.
- For 100 Mbps connections to the ports, use 100-ohm Category 5 UTP or STP cable only, as supported by the IEEE 802.3u Type 100BASE-TX standard.
- For 1000 Mbps connections, 100-ohm Category 5e or better cabling is recommended.

Straight-through Twisted-Pair Cable for 10 Mbps or 100 Mbps Network Connections

Because of the Auto-MDIX operation of the 10/100 ports on the switch, for all network connections, to PCs, servers or other end nodes, or to hubs or other switches, you can use straight-through cables.

If any of these ports are given a fixed configuration, for example 100 Mbps/Full Duplex, the ports operate as MDI-X ports, and straight-through cables must be then used for connections to PC NICs and other MDI ports.

Cable Diagram

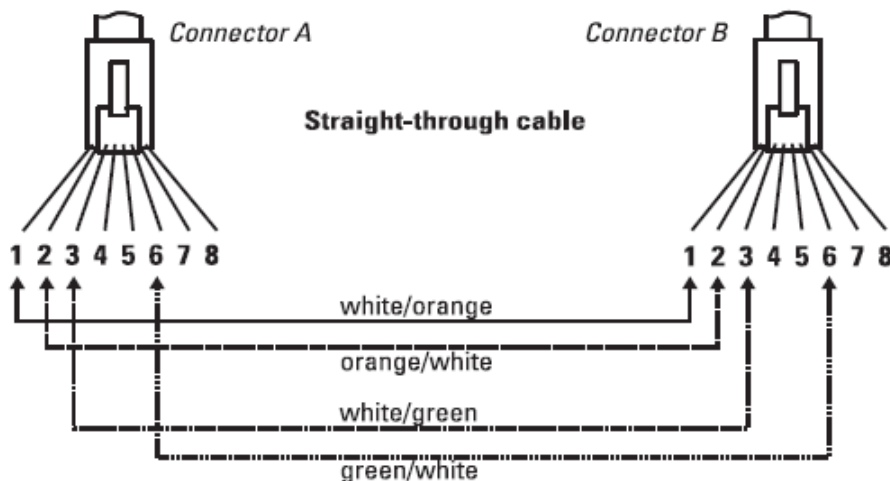

NOTE:

- Pins 1 and 2 on connector “A” *must* be wired as a twisted pair to pins 1 and 2 on connector “B”.
 - Pins 3 and 6 on connector “A” *must* be wired as a twisted pair to pins 3 and 6 on connector “B”.
 - Pins 4, 5, 7, and 8 are not used in this application, although they may be wired in the cable.
-

Pin Assignments

Switch End (MDI-X)		Computer, Transceiver, or Other End (MDI)	
Signal	Pins	Pins	Signal
receive +	1	← 1	transmit +
receive -	2	← 2	transmit -
transmit +	3	→ 3	receive +
transmit -	6	→ 6	receive -

Crossover Twisted-Pair Cable for 10 Mbps or 100 Mbps Network Connection

The Auto-MDIX operation of the 10/100 ports on the switch also allows you to use crossover cables for all network connections, to PCs, servers or other end nodes, or to hubs or other switches.

If any of these ports are given a fixed configuration, for example 100 Mbps/Full Duplex, the ports operate as MDI-X ports, and crossover cables must be then used for connections to hubs or switches or other MDI-X network devices.

Cable Diagram

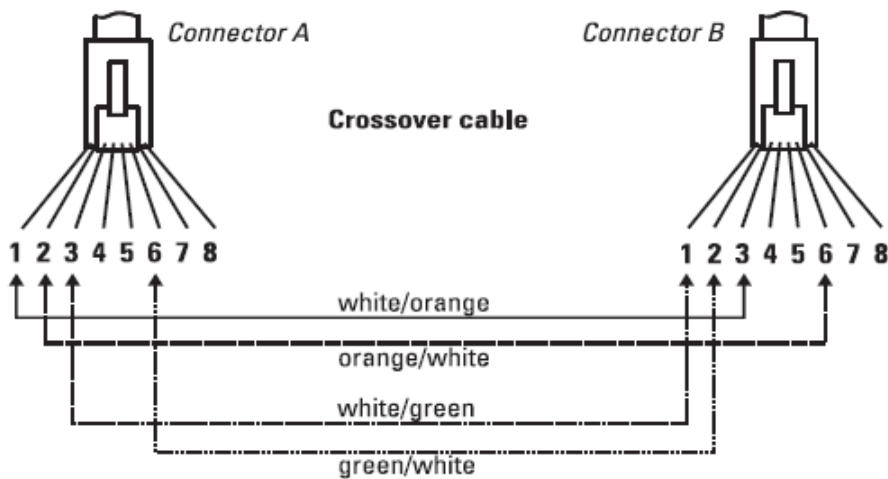

NOTE:

- Pins 1 and 2 on connector "A" *must* be wired as a twisted pair to pins 3 and 6 on connector "B".
- Pins 3 and 6 on connector "A" *must* be wired as a twisted pair to pins 1 and 2 on connector "B".
- Pins 4, 5, 7, and 8 are not used in this application, although they may be wired in the cable.

Pin Assignments

Switch End (MDI-X)		Hub or Switch Port, or Other MDI-X Port End	
Signal	Pins	Pins	Signal
receive +	1	6	transmit -
receive -	2	3	transmit +
transmit +	3	2	receive -
transmit -	6	1	receive +

Straight-Through Twisted-Pair Cable for 1000 Mbps Network Connections

1000BASE-T connections require that all four pairs of wires be connected.

Cable Diagram

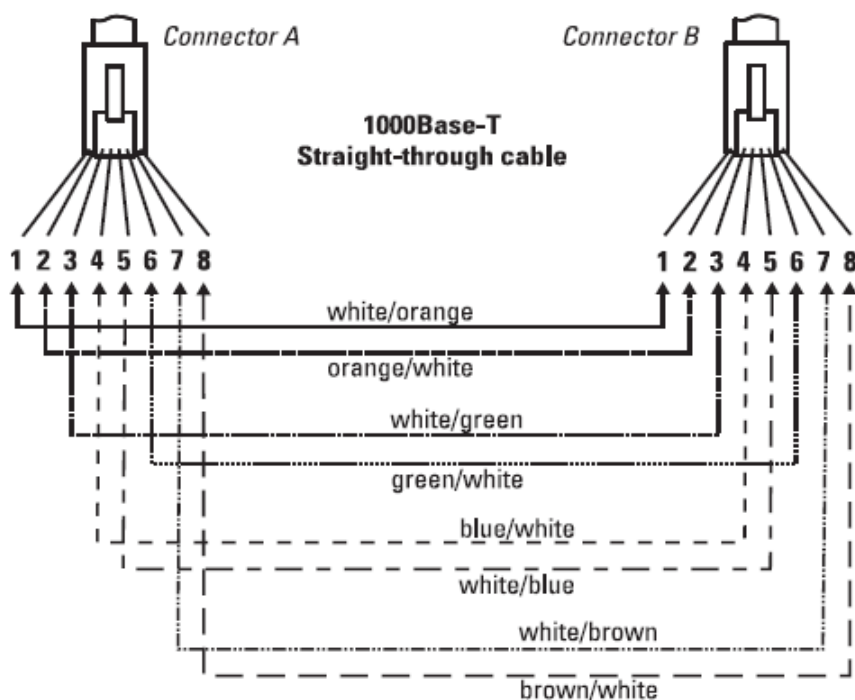

NOTE:

- Pins 1 and 2 on connector "A" *must* be wired as a twisted pair to pins 1 and 2 on connector "B".
- Pins 3 and 6 on connector "A" *must* be wired as a twisted pair to pins 3 and 6 on connector "B".
- Pins 4 and 5 on connector "A" *must* be wired as a twisted pair to pins 4 and 5 on connector "B".
- Pins 7 and 8 on connector "A" *must* be wired as a twisted pair to pins 7 and 8 on connector "B".

Pin Assignments

For 1000BASE-T operation, all four pairs of wires are used for both transmit and receive.

B EMC Regulatory Statements

Regulatory Statements

U.S.A.

FCC Class A

This equipment has been tested and found to comply with the limits for a Class A digital device, pursuant to Part 15 of the FCC Rules. These limits are designed to provide reasonable protection against interference when the equipment is operated in a commercial environment. This equipment generates, uses, and can radiate radio frequency energy and, if not installed and used in accordance with the instruction manual, may cause interference to radio communications. Operation of this equipment in a residential area may cause interference in which case the user will be required to correct the interference at his own expense.

You are cautioned that changes or modifications not expressly approved by the party responsible for compliance could void your authority to operate the equipment.

Canada

This product complies with Class A Canadian EMC requirements.

Australia/New Zealand



This product complies with Australia/New Zealand EMC Class A requirements.

Japan

VCCI Class A

この装置は、クラスA情報技術装置です。この装置を家庭環境で使用すると電波妨害を引き起こすことがあります。この場合には使用者が適切な対策を講ずるよう要求されることがあります。 VCCI-A

Korea

A급 기기 (업무용 방송통신기기)	이 기기는 업무용(A급)으로 전자파적합등록을 한 기기이오니 판매자 또는 사용자는 이 점을 주의하시기 바라며, 가정 외의 지역에서 사용하는 것을 목적으로 합니다.
-----------------------	---

Taiwan

警告使用者：這是甲類的資訊產品，在居住的環境中使用時，可能會造成射頻干擾，在這種情況下，使用者會被要求採取某些適當的對策。

Index

Symbols

10/100BASE-TX ports

location on switch, 6

1000Base-T

1000Base-T

fiber-optic cable specifications, 37

A

acoustic specifications, 36

auto MDI/MDI-X operation, 39, 41

HP Auto-MDIX feature, 38

B

back of switch

power connector, 10

basic troubleshooting tips, 31

blinking LEDs

error indications, 31, 33

buttons

Reset button, 10

C

cabinet

mounting the switch in, 22, 23

cables

connecting cables to switch ports, 26

infrastructure requirements, 18

cables, twisted pair

category 3, 4, 5, 39

cross-over cable pin-out, 41

MDI-X to MDI connections, 39, 41

MDI-X to MDI-X connections, 40

pin-outs, 40, 41

straight-through cable pin-out, 40, 41

switch-to-computer connection, 39, 41

switch-to-switch or hub connection, 40

cables, twisted-pair

HP Auto-MDIX feature, 38

wiring rules, 39

cables, twisted-pair connector pin-outs, 38

cabling infrastructure, 18

Clear button

location on switch, 6

restoring factory default configuration, 10, 33

configuration

restoring factory defaults, 10

connecting the switch to a power source, 25

console port

location on switch, 6

contacting Hewlett Packard Enterprise, 34

cross-over cable

pin-out, 41

D

description

front of switch, 6

LEDs, 9

E

electrical specifications, switch, 35, 36

EMC regulatory statements, 43

environmental specifications, switch, 35

F

factory default configuration, restoring, 10

Fault LED

location on switch, 6

showing error conditions, 31

fiber-optic cables

1000Base-T, 37

front of switch, 6

10/100BASE-TX ports, 6

description, 6

network ports, 8

Reset button, 10

H

horizontal surface

mounting switch on, 24

HP Auto-MDIX

feature description, 38

I

included parts, 13

installation

connecting the switch to a power source, 25

horizontal surface mounting, 24

location considerations, 18

network cable requirements, 18

rack or cabinet mounting, 22, 23

site preparation, 18

L

LEDs

behavior during self test, 20

descriptions of, 9

error indications, 31, 33

Fault

showing error conditions, 31

location on switch, 6

Power, 9

behavior during self test, 21

location for the switch, considerations, 18

M

MDI-X to MDI network cable, 39, 41

MDI-X to MDI-X network cable, 40

mounting the switch

in a rack or cabinet, 22, 23

on a horizontal surface, 24

N

network cables

- HP Auto-MDIX feature, 38
 - required types, 18
 - twisted-pair connector pin-outs, 38
 - twisted-pair, wiring rules, 39
- network devices
 - connecting to the switch, 26
- network ports
 - connecting to, 26
 - location on switch, 8
 - types of, 8

P

- parts, included with the switch, 13
- physical specifications, switch, 35
- pin-outs
 - twisted-pair cables, 38
- PoE LED patterns, 33
- PoE troubleshooting, 33
- port LEDs
 - normal operation, 21
- ports
 - connecting to, 26
 - HP Auto-MDIX feature, 38
 - network connections, 26
- power connector, 10
- Power LED, 9
 - behavior during self test, 21
 - behaviors, 9
 - location on switch, 6
- power source
 - connecting the switch to, 25
- Power-over-Ethernet
 - PoE power, 8
- preparing the installation site, 18

R

- rack
 - mounting the switch in, 22, 23
- regulatory statements, 43
- Reset button
 - description, 10
 - location on switch, 6, 10
 - restoring factory default configuration, 33
- resetting the switch
 - location of Reset button, 10

S

- safety and regulatory statements, 43
- safety specifications, 36
- self test
 - LED behavior during, 20
 - Power LED behavior, 21
- SFPs
 - slot, location on switch, 6
- slots for SFPs
 - location on switch, 6
- specifications
 - acoustic, 36
 - electrical, 35, 36

- environmental, 35
 - physical, 35
 - safety, 36
- straight-through cable
 - pin-out, 40, 41
- support
 - Hewlett Packard Enterprise, 34
- switch
 - connecting to a power source, 25
 - electrical specifications, 35, 36
 - environmental specifications, 35
 - front panel description, 6
 - included parts, 13
 - mounting in a rack or cabinet, 22, 23
 - mounting on horizontal surface, 24
 - physical specifications, 35
- switch operation
 - verifying after installation, 19

T

- tips for troubleshooting, 31
- troubleshooting, 31
 - basic tips, 31
 - common network problems, 31
- twisted-pair cable
 - cross-over cable pin-out, 41
 - pin-outs, 38, 40, 41
 - straight-through cable pin-out, 40, 41
 - switch-to-computer connection, 39, 41
 - switch-to-switch or hub connection, 40
- twisted-pair ports
 - HP Auto-MDIX feature, 38

W

- wiring rules for twisted-pair cables, 39